



An American Control Electronics Brand

DC30-12/24-4Q-W

4Q PWM Microprocessor-based Chassis
Adjustable Speed Drive w/ WigWag Control
for Low Voltage PMDC Brush Motors

Specifications

Model	Source Voltage (VDC)	Armature Voltage Range (VDC)	Peak Armature Current (Amps)	Motor Horsepower Range
DC30-12/24-4Q-W	12 24 of Source Voltage	Up to 95%	30*	1/50 - 1/6 1/25 - 1/3

* Peak current rating for 1 minute. Continuous current rating is 15 amps.

Source Voltage.....	8 - 32 VDC
Form Factor.....	1.01 at base speed
Acceleration Time Range.....	0.5 - 16 seconds
Deceleration Time Range.....	0.5 - 16 seconds
Analog Input Voltage Range.....	0 - 5 VDC
Input Impedance (Terminal 3 to 2).....	>100k ohms
Load Regulation.....	1% base speed
Speed Range.....	100:1
Vibration (0 - 50 Hz).....	0.5G maximum
(>50 Hz).....	0.1G maximum
Ambient Temperature Range.....	0°C - 55°C
Weight.....	0.4 lbs

Safety Warnings

READ ALL SAFETY WARNINGS BEFORE INSTALLING THIS EQUIPMENT

- **DO NOT INSTALL, REMOVE, OR REWIRE THIS EQUIPMENT WITH POWER APPLIED.** Have a qualified electrical technician install, adjust and service this equipment. Follow the National Electrical Code and all other applicable electrical and safety codes, including the provisions of the Occupational Safety and Health Act (OSHA), when installing equipment.
- Avoid direct contact with the printed circuit board or with circuit elements to prevent the risk of serious injury or fatality. Use a non-metallic screwdriver for adjusting the calibration trim pots. Use approved personal protection equipment and insulated tools if working on this drive with power applied.
- The drive is not diode-protected from reverse battery voltage. You must ensure that the positive terminal is wired to POS and the negative terminal is wired to NEG.
- Reduce the chance of an electrical fire, shock, or explosion by using proper grounding techniques, over-current protection, thermal protection, and enclosure. Follow sound maintenance procedures.
- **Removing DC power is the only acceptable method for emergency stopping.** Do not use regenerative braking, decelerating to minimum speed, or coasting to a stop for emergency stopping. They may not stop a drive that is malfunctioning. Removing DC power is the only acceptable method for emergency stopping.
- Applying and removing DC source voltage is recommended for infrequent starting and stopping of a drive only. Regenerative braking, decelerating to minimum speed, or coasting to a stop is recommended for frequent starts and stops. Frequent starting and stopping can produce high torque. This may cause damage to motors.
- **Do not disconnect any of the motor leads from the drive** unless power is removed or the drive is disabled. Opening any one lead while the drive is running may destroy the drive.
- Under no circumstances should power and logic level wires be bundled together.
- Be sure potentiometer tabs do not make contact with the potentiometer's body. Grounding the input may cause damage to the drive.
- This product does not have internal solid state motor overload protection. It does not contain speed-sensitive overload protection, thermal memory retention, or provisions to receive and act upon signals from remote devices for over temperature protection. If motor protection is needed in the end-use product, it needs to be provided by additional equipment in accordance with NEC standards.

Dimensions

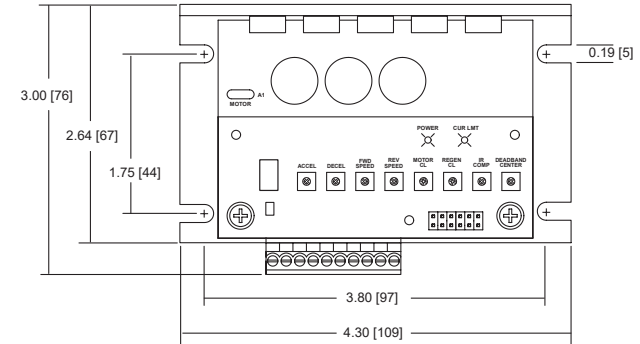

Height = 1.41 [35.8]

ALL DIMENSIONS IN INCHES [MILLIMETERS]

Installation

Mounting

- Drive components are sensitive to electrostatic discharge. Avoid direct contact with the circuit components.
- Protect the drive from dirt, moisture, and accidental contact.
- Provide sufficient room for access to the terminal block and calibration trim pots.
- Mount the drive away from heat sources. Operate the drive within the specified ambient operating temperature range.
- Prevent loose connections by avoiding excessive vibration of the drive.
- Mount the drive with its board in either a horizontal or vertical plane. Six 0.15" (4 mm) wide slots in the chassis accept #8 pan head screws. Fasten either the large base or the narrow flange of the chassis to the subplate.
- The chassis should be earth grounded when possible.

Wiring

Use 18 - 24 AWG wire for logic wiring.
Use 10 - 12 AWG wire for DC source (POS, NEG) and motor (A1, A2) wiring.

Shielding Guidelines

As a general rule, it is recommended to shield all conductors. If it is not practical to shield power conductors, it is recommended to shield all logic-level leads. If shielding of logic-level leads is not practical, the user should twist all logic leads with themselves to minimize induced noise. It may be necessary to earth ground the shielded cable. If noise is produced by devices other than the drive, ground the shield at the drive end. If noise is generated by the drive, ground the shield at the end away from the drive. Do not ground both ends of the shield.

Fusing

The drive requires an external line fuse for protection. Use fast acting fuses rated for at least 150% of the maximum armature voltage and current. Fuse the positive terminal.

Connections

Input Power

Connect the DC input power leads to terminals POS (positive) and NEG (negative).
Connecting the DC input power backwards will cause damage to the drive.

Motor

Connect the DC armature leads to terminals A1 and A2. If the motor does not spin in the desired direction, power down the drive and reverse these connections.

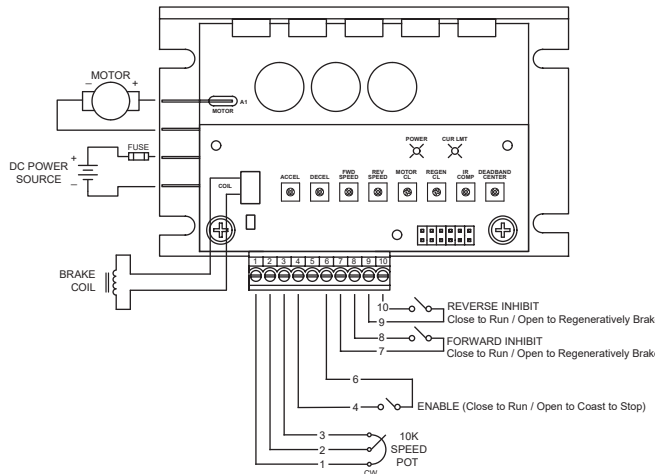

Speed Potentiometer

Use a 10K ohm, 1/4 W potentiometer for speed control. Connect the counter-clockwise end of the potentiometer to terminal 3, the wiper to terminal 2, and the clockwise end to terminal 1. Setting the potentiometer fully CCW will run the motor in full speed reverse. Setting the potentiometer fully CW will run the motor in full speed forward. The position of the potentiometer corresponding to a zero speed command is determined by the DEADBAND CENTER trim pot. If the potentiometer works inversely of desired functionality, (i.e. to run forward, you must turn the potentiometer CCW), power off the drive and swap the terminal 1 and 3 connections.

Analog Signal

If using an analog input signal of 0 - 5 VDC, connect the signal common / negative (-) to terminal 3 and the signal reference / positive (+) to terminal 2. The drive is not isolated and the common terminal 3 is connected to battery negative. 0 VDC corresponds to full speed reverse, 5 VDC corresponds to full speed forward, and the zero speed VDC is determined by the DEADBAND CENTER trim pot.

Forward & Reverse Inhibit

Connect a forward inhibit switch to terminals 7 and 8 and a reverse inhibit switch to terminals 9 and 10. Opening a connection regeneratively brakes the motor to a stop. The inhibits bypass the DECEL trim pot. The forward inhibit switch has no effect if the motor is running in reverse, and vice versa. If the use of only one inhibit switch is desired, jumper terminals 7 and 9 and then connect the switch to either the forward or reverse inhibit input. If no inhibit switches are desired, jumper terminals 7 and 8 and jumper terminals 9 and 10. **Do not use the Inhibit functions for emergency stopping.**

Enable

Connect an enable switch to terminals 4 and 6. Close the connection to run and open the connection to coast the motor to a stop. The enable comes into effect regardless of direction. If no switch is desired, jumper terminals 4 and 6. **Do not use the Enable function for emergency stopping.**

Coil

The COIL terminals supply a voltage out to an electro-mechanical DC brake. The voltage is removed after a short delay once the enable is opened, an inhibit input is opened, or the speed of the motor is set to zero. The voltage is reapplied to the COIL terminals once a run command has been received. The voltage is equal to the input power voltage.

Startup

STARTUP

- Verify that no foreign conductive material is present on the printed circuit board.

1. If using a speed adjust potentiometer, set it to the position corresponding to zero motor speed (typically 12 o'clock / midposition). If using an analog signal, set it for voltage corresponding to zero motor speed (typically 50%, 2.5 VDC).
2. Apply the DC source voltage.
3. Close the Enable switch.
4. Slowly advance the speed adjust potentiometer clockwise (CW) or increase the analog signal. The motor should accelerate. Continue until the desired speed is reached.
5. Remove the DC source voltage. The motor should coast to a stop.

LEDs

TOP BOARD LEDs

Current Limit (CURR LIMIT): Red LED turns on whenever the drive reaches current limit.
Power (POWER): Green LED turns on whenever DC source voltage is applied to the drive.

BOTTOM BOARD LEDs

Status LEDs - Over Voltage: Green and red LEDs flash quickly.
 The source voltage is too high (greater than 32 VDC).
Under Voltage: Green LED flashes slowly. Motor output is disabled.
 The source voltage is too low (less than 7.5 VDC).
Over Temperature: Green LED flashes quickly. Motor output is disabled.
 The ambient temperature is too high (greater than 55°C).
Thermal Foldback: Red LED flashes quickly. Ambient temperature reached 75°C. Drive will lower current limit until the ambient temperature lowers to an acceptable operating temperature.

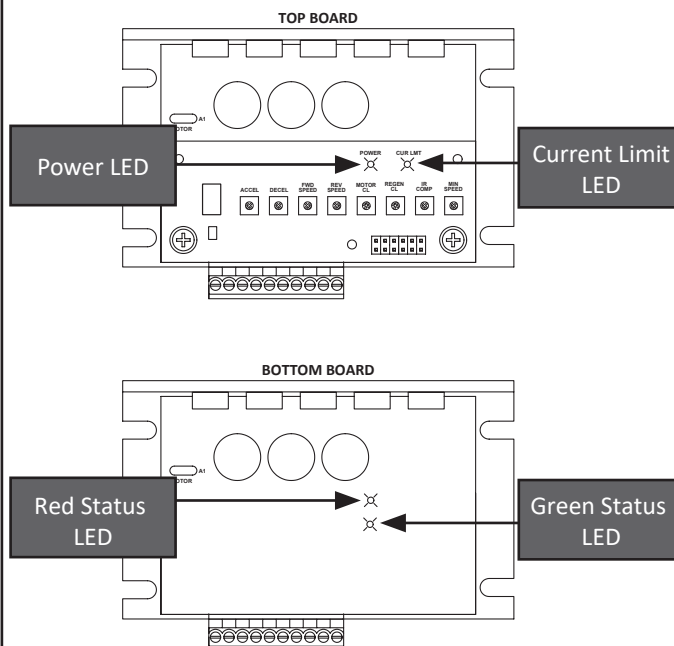

Calibration

Minimum Speed (DEADBAND CENTER): The DEADBAND CENTER setting determines the speed potentiometer location / analog voltage level that commands zero speed. To calibrate the DEADBAND CENTER:

1. Disable the drive and set the DEADBAND CENTER trim pot to 50%.
2. Set the speed adjust potentiometer for the desired zero speed command position, or if using an analog signal, set it to the desired zero speed command voltage (typically 50% or 2.5 VDC).
3. Enable the drive and adjust the DEADBAND CENTER until the motor runs at zero speed.

Forward Maximum Speed (FWD SPEED): The FWD SPEED setting determines the maximum motor speed in the forward direction (when A1 is positive with respect to A2). To calibrate the FWD SPEED:

1. Set the FWD SPEED trim pot full CCW.
2. Set the speed adjust potentiometer for maximum speed.
3. Adjust FWD SPEED until the desired maximum speed is reached.

Reverse Maximum Speed (REV SPEED): The REV SPEED setting determines the maximum motor speed in the reverse direction (when A2 is positive with respect to A1). To calibrate the REV SPEED:

1. Set the REV SPEED trim pot full CCW.
2. Set the speed adjust potentiometer for maximum speed.
3. Adjust REV SPEED until the desired maximum speed is reached.

Motoring Torque (MOTOR CL): The MOTOR CL setting determines the maximum torque for accelerating and driving the motor in the forward or reverse directions. To calibrate the MOTOR CL:

1. With the power disconnected from the drive, connect a DC ammeter in series with the armature.
2. Set the MOTOR CL trim pot to minimum (full CCW).
3. Set the speed adjust potentiometer to maximum forward speed (full CW).
4. Carefully lock the motor armature. Be sure that the motor is firmly mounted.
5. Apply power source. The motor should be stopped.
6. Slowly adjust the MOTOR CL trim pot CW until the armature current is 150% of motor rated armature current.
7. Turn the speed adjust potentiometer to minimum speed (full CCW).
8. Remove power source.
9. Remove the stall from the motor.
10. Remove the ammeter in series with the motor armature if it is no longer needed.

Alternatively, see the approximate settings below.

	5.0 Amps at 12 VDC 7.5 Amps at 24 VDC		28.0 Amps at 12 VDC 29.0 Amps at 24 VDC		44.0 Amps at 12 VDC 48.0 Amps at 24 VDC
	9.0 Amps at 12 VDC 12.5 Amps at 24 VDC		34.0 Amps at 12 VDC 36.0 Amps at 24 VDC		
	17.5 Amps at 12 VDC 21.0 Amps at 24 VDC		41.0 Amps at 12 VDC 44.0 Amps at 24 VDC		

Regening Torque (REGEN CL): The REGEN CL setting determines the maximum torque for decelerating the motor and resisting an overhauling load in the forward or reverse directions. Turn the REGEN CL trim pot CW to increase the regen current limit and CCW to decrease the regen current limit. See the approximate settings below.

	3.5 Amps at 12 VDC 5.0 Amps at 24 VDC		19.0 Amps at 12 VDC 20.0 Amps at 24 VDC		37.0 Amps at 12 VDC 40.0 Amps at 24 VDC
	6.0 Amps at 12 VDC 7.0 Amps at 24 VDC		28.0 Amps at 12 VDC 29.0 Amps at 24 VDC		
	12.5 Amps at 12 VDC 15.0 Amps at 24 VDC		32.0 Amps at 12 VDC 35.0 Amps at 24 VDC		

IR Compensation (IR COMP): The IR COMP setting determines the degree to which motor speed is held constant as the motor load changes. To calibrate the IR COMP:

1. Set the IR COMP trim pot full CCW.
2. Increase the speed adjust potentiometer until the motor runs at midspeed without load. A handheld tachometer may be used to measure motor speed.
3. Load the motor armature to its full load armature current rating. The motor should slow down.
4. While keeping the load on the motor, rotate the IR COMP trim pot until the motor runs at the speed measured in step 2. If the motor oscillates (overcompensation), the IR COMP trim pot may be set too high (CW). Turn the IR COMP trim pot CCW to stabilize the motor.
5. Unload the motor.

Acceleration (ACCEL): The ACCEL setting determines the time the motor takes to ramp to a higher speed. To calibrate the ACCEL, turn the ACCEL trim pot CW for a longer acceleration time and CCW for a shorter acceleration time.

Deceleration (DECEL): The DECEL setting determines the time the motor takes to ramp to a lower speed. To calibrate the DECEL, turn the DECEL trim pot CW for a longer deceleration time and CCW for a shorter deceleration time.